

ACCESSORIES for Sanding, Grinding, Polishing



Who We Are

We are Yongkang Meiloy-K&FP Tools Co.,Ltd., a Specialist Business within the Meiloy Group of Companies, working to meet the needs of surface processing around the world. Established in 2005, we are now the leading supplier for various kinds of accessories for sanding, grinding and polishing works.

Our Mission is to produce leading edge, innovative products, which add tangible commercial benefits to the businesses of our customers.

Our Products are designed to improve the performance by extending life, increasing throughput, maximising availability and reducing operating costs.

We won because we are committed to innovation and technical excellence, focused 100% on meeting the needs of our customers.

We are a multi-disciplinary company, with exceptional staff and technical resources.

We work as partners with many of the world's leading abrasive & car care companies for years.

Our Advantages

TECHNOLOGY – With state-of-art facilities, we are able to offer the Premium Quality and Process Control.

QUICK DELIVERY – we have full spares backup and workshop facilities.

QUALITY CONTROL – Your satisfaction is guaranteed, strict quality control is adopted in all processes of production.

OEM/ODM – we can make customized logo on the products. We also work on customized new design.

INTERNATIONAL – providing global support for customers, through our network of distribution partners and regional offices.

SERVICES – providing a comprehensive range of site services for distributors worldwide.



Yongkang MEiLOY-K&FP Tools Co.,Ltd.

Add: No.26 Huahai Road, New Western City District, Yongkang City, Zhejiang, China





Tel: +86-579-87182802

Fax: +86-579-87208230

E-mail: sales@sunnypads.cn

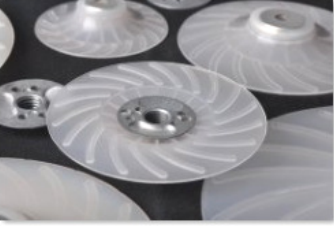
http://www.SunnyPads.cn

Contents	Page
Rotary Sander/Polisher Pads	1.1 - 1.3
Backing Pads For Resin Fibre Discs	2.1
DA Backing pads Interface Pads	3.1 - 3.9
Roloc Disc Holder and Pads	4.1
Drill Pads and Adaptors	5.1
Hand Pads	6.1 - 6.3
Stone Working Pads Felt Mops	7.1
Foam Pads	8.1 - 8.5
Wool Pads	9.1 - 9.3
Backing Pads FlexEdge	10.1 - 10.2
Miscellaneous	11.1

<u>Products</u>	<u>Page</u>	<u>Content</u>
Rotary Sander/Polisher Pads 	1.1 1.2 1.3	Rotary Pad High Profile Rotary Pad Middle Profile Rotary Pads Laminated
Backing Pads For Resin Fibre Discs 	2.1-2.2	Spiral Cool
DA Backing Pads, Interface Pads 	3.1-3.2 3.3 3.4 3.5 3.6 3.7 3.8 3.9	DA Pads Introductions Classic DA Pads Pro-Quality DA Pads DA Pads 1-3.5 inch Dust Free DA Pads Dust Devil™ V3 DA Pads Dust Devil™ V2 DA Pads Interface Pads
Roloc Disc Holders and Pads 	4.1	Roloc Disc Holder and Pads
Drill Pads and Adaptors 	5.1	Drill Pads and Adaptors

Hand Pads



6.1-6.3

Hand Pads

Stone Working Pads, Felt Mops



7.1

Stone Working Pad and Felt Mops

Foam pads



8.1

Types of Foam

8.2

Foam Pads with non-recessed velcro

8.3

Foam pads with recessed velcro

8.4

9" Diamond Foam Pads

8.5

Wax Applicator , Car Wash Foam & Polishing Cone



Wool Pads



9.0

Types of Wool

9.1-9.2

Wool Pads

Backing Pads for Foam Pad and Wool Buffing Pads



10.1

Rotary Pads FlexEdge

10.2

Backing Pads for Foam Pad and Wool Buffing Pads

Miscellaneous



11.1

Palm Sander Backing Pads

1.1 Rotary Pad High Profile

High Profile Soft Backing pads for contour polishing

PUR molded, soft, good rebounding and durability.
 Ideal for contour face polishing, e.g. car body, fiberglass piece, boat, floor etc.
 Suggested to work with lambswool pads, foam pads and abrasive discs .



Item No.	Size	Thread	Velcro	PSA	Max.RPM	Density	Thickness
14222-12	2" (50mm)	5/8"-11	✓		12000	Soft	22mm
14222-22	2" (50mm)	M14-2	✓		12000	Soft	22mm
14232-12	3" (70mm)	5/8"-11	✓		12000	Soft	22mm
14232-22	3" (70mm)	M14-2	✓		12000	Soft	22mm



Item No.	Size	Thread	Velcro	PSA	Max.RPM	Density	Thickness
14350-11	5" (123mm)	5/8"-11		✓	8000	Soft	27.5mm
14350-12	5" (123mm)	5/8"-11	✓		8000	Soft	27.5mm
14350-21	5" (123mm)	M14-2		✓	8000	Soft	27.5mm
14350-22	5" (123mm)	M14-2	✓		8000	Soft	27.5mm
14350-31	5" (123mm)	M16-2		✓	8000	Soft	27.5mm
14350-32	5" (123mm)	M16-2	✓		8000	Soft	27.5mm
16360-12	6" (148mm)	5/8"-11	✓		5000	Soft	29mm
16360-22	6" (148mm)	M14-2	✓		5000	Soft	29mm
16360-32	6" (148mm)	M16-2	✓		5000	Soft	29mm



Item No.	Size (D)	Thread	Face	Max.RPM	Density	Thickness
16365-TF	7" (166mm)	T	F	5000	Soft	32mm
16380-TF	8" (200mm)	T	F	4500	Soft / Medium	34mm

T (Thread)	1=5/8"-11	F (Face)	1=PSA
	2=M14-2		2=Velcro
	3=M16-2		3=Canvas



1.2 Rotary Pad Middle Profile

Middle Profile Backing pads for general polishing job

PUR molded, good rebounding and durability.

Available densities: Soft (White PUR) , Medium (Yellow PUR)



Item No.	Size	Thread	Velcro	PSA	Max.RPM	Density	Thickness
14231-22	3" (74mm)	M14-2	✓		12000	Soft	13.5mm
14231-32	3" (74mm)	M10-1.5	✓		12000	Soft	13.5mm

Item No.	Size	Thread	Velcro	PSA	Max.RPM	Density	Thickness
14240-22	4" (98mm)	M14-2	✓		12000	Medium	15.5mm
14240-32	4" (98mm)	M10-1.5	✓		12000	Medium	15.5mm
14245-12	4.5" (113mm)	5/8"-11	✓		10000	Medium	15.5mm
14245-22	4.5" (113mm)	M14-2	✓		10000	Medium	15.5mm
14250-12	5" (123mm)	5/8"-11	✓		10000	Medium	15.5mm
14250-22	5" (123mm)	M14-2	✓		10000	Medium	15.5mm
14260-12	6" (148mm)	5/8"-11	✓		7000	Medium	15.5mm
14260-22	6" (148mm)	M14-2	✓		7000	Medium	15.5mm

Item No.	Size	Thread	Velcro	PSA	Max.RPM	Density	Thickness
14270-12	7" (178mm)	5/8"-11	✓		5000	Medium	13.5mm
14270-22	7" (178mm)	M14-2	✓		5000	Medium	13.5mm
14270-32	7" (178mm)	M16-2	✓		5000	Medium	13.5mm

Item No.	Size	Thread	Velcro	PSA	Max.RPM	Density	Thickness
16040-22	4" (100mm)	M14-2	✓		12000	Medium	15.5mm
16040-32	4" (100mm)	M10-1.5	✓		12000	Medium	15.5mm
16045-12	4.5" (113mm)	5/8"-11	✓		10000	Medium	15.5mm
16045-22	4.5" (113mm)	M14-2	✓		10000	Medium	15.5mm
16050-12	5" (122mm)	5/8"-11	✓		10000	Medium	15.5mm
16050-22	5" (122mm)	M14-2	✓		10000	Medium	15.5mm
16050-21	5" (122mm)	M14-2		✓	10000	Medium	15.5mm
16060-12	6" (148mm)	5/8"-11	✓		7000	Medium	15.5mm
16060-22	6" (148mm)	M14-2	✓		7000	Medium	15.5mm
16060-21	6" (148mm)	M14-2		✓	7000	Medium	15.5mm

1.3 Rotary Pads Laminated

Laminated Backing pad for general-purpose sanding/polishing

With nylong support backing plate, laminated with soft EVA foam



Item No.	Size	Thread	Velcro	PSA	Max.RPM	Density	Foam Thickness
14110-31	1" (25mm)	M10-1.5		✓	12000	Medium	10mm
14110-32	1" (25mm)	M14-2	✓		12000	Medium	10mm
14120-21	2" (50mm)	M14-2		✓	12000	Medium	10mm
14120-31	2" (50mm)	M10-1.5		✓	12000	Medium	10mm
14120-12	2" (50mm)	5/8"-11	✓		12000	Medium	10mm
14120-22	2" (50mm)	M14-2	✓		12000	Medium	10mm
14120-32	2" (50mm)	M10-1.5	✓		12000	Medium	10mm
14130-11	3" (74mm)	5/8"-11		✓	12000	Medium	10mm
14130-21	3" (74mm)	M14-2		✓	12000	Medium	10mm
14130-12	3" (74mm)	5/8"-11	✓		12000	Medium	10mm
14130-22	3" (74mm)	M14-2	✓		12000	Medium	10mm

* Remark: Optional streight or bevel cut edge and water feed hole



Item No.	Size	Thread	Velcro	PSA	Max.RPM	Remark	Foam Thickness
11040-1	4" (100mm)	M10-1.5	✓		12000	Medium	10mm
11045-2	4.5" (115mm)	M14-2	✓		12000	Medium	10mm
11050-2	5" (125mm)	M14-2	✓		12000	Medium	10mm
11060-2	6" (150mm)	M14-2	✓		10000	Medium	10mm

* Remark: Optional streight or bevel cut edge and water feed hole



Item No.	Size	Thread	Velcro	PSA	Max.RPM	Density	Foam Thickness
14165-1	6.5" (165mm)	5/8"-11	✓		6000	Medium	10mm
14165-2	6.5" (165mm)	M14-2	✓		6000	Medium	10mm
14165-3	6.5" (165mm)	M16-2	✓		6000	Medium	10mm

2.1 Backing pads for Resin Fibre Discs

Spiral Cool Backing pads for Resin Fibre Discs



Features:

- Work with right angle grinders or polishing machines
- Pad built with spiral cooling ribs
- Metal Zinc-alloy clamping nut included
- Built of high impact-resistant material to withstand aggressive working
- Customized flexibility and color available upon request .

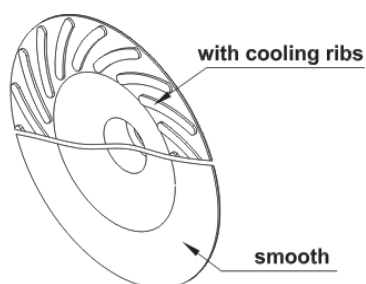
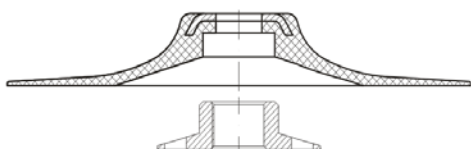

Item No.	Diameter	Thread	Abrasive	Flexibility	Face	Color	Max.RPM
61040-121	92mm	5/8"-11	4"	Medium	Spiral Ribs	White	15000
61040-221	92mm	M14-2	4"	Medium	Spiral Ribs	White	15000
61040-421	92mm	M10-1.5	4"	Medium	Spiral Ribs	White	15000
61045-121	108mm	5/8"-11	4.5"	Medium	Spiral Ribs	White	13000
61045-221	108mm	M14-2	4.5"	Medium	Spiral Ribs	White	13000
61050-121	117mm	5/8"-11	5"	Medium	Spiral Ribs	White	12000
61050-221	117mm	M14-2	5"	Medium	Spiral Ribs	White	12000
61070-121	172mm	5/8"-11	7"	Medium	Spiral Ribs	White	8000
61070-221	172mm	M14-2	7"	Medium	Spiral Ribs	White	8000

Remark:

The pad is supplied with a clamping nut.

Smooth face pad is available for customized orders only.

Clamping Nut

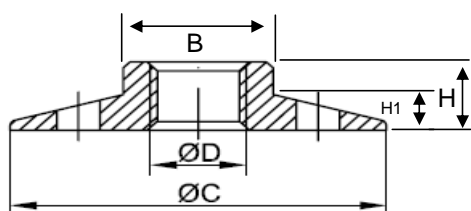

Item No.	C	D	H	H1	B	Material	For Pad
CN-44L-5/8	44 mm	5/8"-11	9.5 mm	2mm	22 mm	Zinc-Alloy	4"-8"
CN-44L-M14	44 mm	M14-2	9.5 mm	2mm	22 mm	Zinc-Alloy	4"-8"
CN-44L-M10	44 mm	M10-1.5	9.5 mm	2mm	22 mm	Zinc-Alloy	4"-8"

3.1 DA Pads Introductions

Dual Actional Sander Backing Pads



Features:

- PUR molded, good flexibility and durability.
- One-piece bolt, strong and precise
- Well controlled balance and weight for vibration-free operation
- Wide range of sizes, hole configuration, hardness and thickness available to meet particular demand

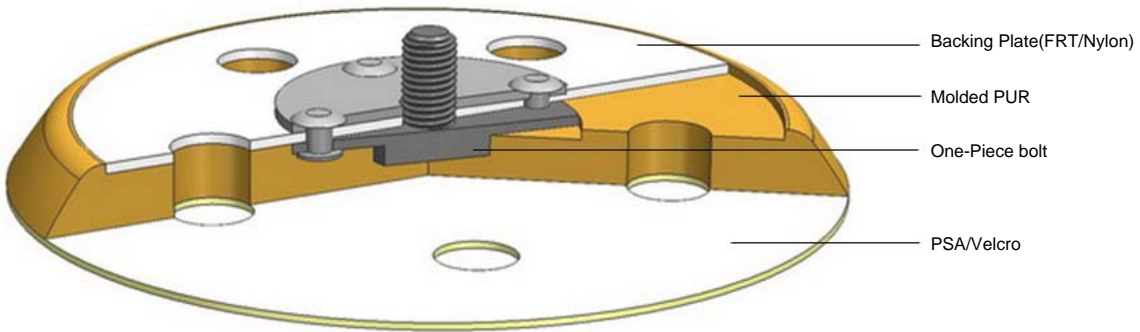

5" Pad Hole Configurations

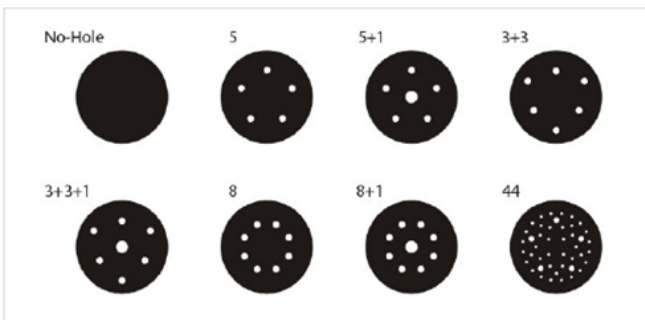

6" Pad Hole Configurations

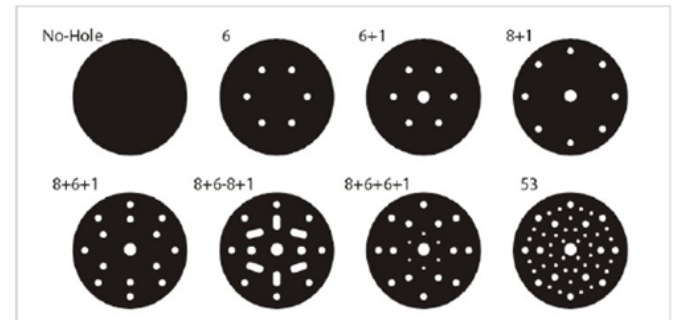

3.2 DA Pads Introductions

Available Thickness for DA backing pads :

Low Profile, 5" and 6" Pads
Foam Thickness 8.5mm
Bevel Edge

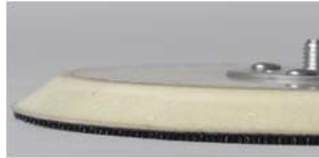

Low Profile, 5" and 6" Pads
Foam Thickness 8.7mm
Straight Edge

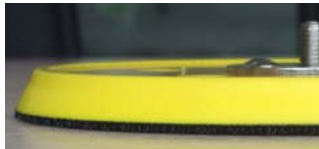

Low Profile, 5" and 6" Pads
Foam Thickness 10mm
Bevel Edge



Middle Profile, 5" and 6" Pads
Foam Thickness 9.5mm
Slight-Bevel Edge



Middle Profile, 5" and 6" Pads
Foam Thickness 11.5mm
Bevel Edge

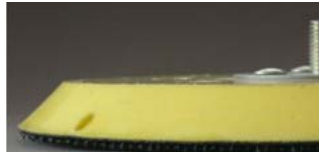

Middle Profile, 6" Pads
Foam Thickness 12mm
Slight-Bevel Edge



Middle Profile, 5" and 6" Pads
Foam Thickness 14.5mm
Bevel Edge



Two Layer Middle Profile, 6" Pads
Foam Thickness 14mm
Slight-Bevel Edge



High Profile, 5" and 6" Pads
Foam Thickness 27mm
Bevel Edge



Low Profile, 1.2" Pads
Foam Thickness 10mm
Slight-Bevel Edge



Low Profile, 2" Pads
Foam Thickness 9mm
Straight Edge



Low Profile, 3"
Foam Thickness 10mm
Bevel Edge



Middle Profile, 3" Pads
Foam Thickness 10mm
Bevel Edge



Middle Profile, 3" and 4" Pads
Foam Thickness 13mm
Straight Edge



Middle Profile, 3.5" Pads
Foam Thickness 13mm
Bevel Edge



High Profile, 3" Pads
Foam Thickness 20mm
Bevel Edge



3.3 Classic DA Pads

Dual Action Sander Backing Pads, low profile

PUR molded, Medium density , good rebounding and durability.
Pad with fixed 5/16"-24 bolt



Item No.	Size	Thread	Velcro	PSA	Max.RPM	Density	Hole	Weight	Thickness
21040-2	4" (98mm)	5/16"-24	✓		12000	Medium	no hole	100g	14.5mm
21050-1	5" (123mm)	5/16"-24		✓	12000	Medium	no hole	100g	9.5mm
21050-2	5" (123mm)	5/16"-24	✓		12000	Medium	no hole	100g	9.5mm
21150-1	5" (123mm)	5/16"-24		✓	12000	Medium	3+3	100g	9.5mm
21150-2	5" (123mm)	5/16"-24	✓		12000	Medium	3+3	100g	9.5mm
21250-1	5" (123mm)	5/16"-24		✓	12000	Medium	5	100g	9.5mm
21250-2	5" (123mm)	5/16"-24	✓		12000	Medium	5	100g	9.5mm
21350-1	5" (123mm)	5/16"-24		✓	12000	Medium	8	100g	9.5mm
21350-2	5" (123mm)	5/16"-24	✓		12000	Medium	8	100g	9.5mm



Item No.	Size	Thread	Velcro	PSA	Max.RPM	Density	Hole	Weight	Thickness
21060-1	6" (148mm)	5/16"-24		✓	12000	Medium	no hole	125g	9.5mm
21060-2	6" (148mm)	5/16"-24	✓		12000	Medium	no hole	125g	9.5mm
21160-1	6" (148mm)	5/16"-24		✓	12000	Medium	6	125g	9.5mm
21160-2	6" (148mm)	5/16"-24	✓		12000	Medium	6	125g	9.5mm

Dual Action Sander Backing Pads, Middle Profile, Bevel Edge

PUR molded, Medium density , good rebounding and durability.
Pad with fixed 5/16"-24 bolt



Item No.	Size	Thread	Velcro	PSA	Max.RPM	Density	Hole	Weight	Thickness
22050-1	5" (123mm)	5/16"-24		✓	12000	Medium	no hole	100g	14.5mm
22050-2	5" (123mm)	5/16"-24	✓		12000	Medium	no hole	100g	14.5mm
22250-1	5" (123mm)	5/16"-24		✓	12000	Medium	5	100g	14.5mm
22250-2	5" (123mm)	5/16"-24	✓		12000	Medium	5	100g	14.5mm
22060-1	6" (148mm)	5/16"-24		✓	12000	Medium	no hole	125g	14.5mm
22060-2	6" (148mm)	5/16"-24	✓		12000	Medium	no hole	125g	14.5mm

3.4 Pro-Quality DA Backing Pads



The backing pad is the key component for building a non-vibration air sander. SunnyPads works with many world-class pneumatic manufacturers closely, developed a specially designed series of pads for tool factory supply. For its outstanding performance, we call this series of pad as Pro-Quality .

Straight Edge DA Backing Pads



Item No.	Size	Thread	Velcro	PSA	Max.RPM	Density	Hole	Weight	Thickness
23050-1	5" (123mm)	5/16"-24		✓	12000	Medium	no hole	100g	8.7mm
23050-2	5" (123mm)	5/16"-24	✓		12000	Medium	no hole	100g	8.7mm
23250-1	5" (123mm)	5/16"-24		✓	12000	Medium	5	100g	8.7mm
23250-2	5" (123mm)	5/16"-24	✓		12000	Medium	5	100g	8.7mm
23060-1	6" (148mm)	5/16"-24		✓	12000	Medium	no hole	125g	8.7mm
23060-2	6" (148mm)	5/16"-24	✓		12000	Medium	no hole	125g	8.7mm
23160-1	6" (148mm)	5/16"-24		✓	12000	Medium	6	125g	8.7mm
23160-2	6" (148mm)	5/16"-24	✓		12000	Medium	6	125g	8.7mm

Remark: Use J-hook velcro.

Bevel Edge DA Backing Pads



Item No.	Size	Thread	Velcro	PSA	Max.RPM	Density	Hole	Weight	Thickness
23550-1	5" (123mm)	5/16"-24		✓	12000	Medium	no hole	100g	8.7mm
23550-2	5" (123mm)	5/16"-24	✓		12000	Medium	no hole	100g	8.7mm
23555-1	5" (123mm)	5/16"-24		✓	12000	Medium	5	100g	8.7mm
23555-2	5" (123mm)	5/16"-24	✓		12000	Medium	5	100g	8.7mm
23560-1	6" (148mm)	5/16"-24		✓	12000	Medium	no hole	125g	8.7mm
23560-2	6" (148mm)	5/16"-24	✓		12000	Medium	no hole	125g	8.7mm
23566-1	6" (148mm)	5/16"-24		✓	12000	Medium	6	125g	8.7mm
23566-2	6" (148mm)	5/16"-24	✓		12000	Medium	6	125g	8.7mm

Remark: Use micro hook velcro.



The Pro-Quality level DA pads are designed and manufactured specially for professional air sander building, the pads are 100% tested and they are assured to be in compliance with high requirement of strength, run-out, balance, weight, flatness, and also less vibration.

3.5 DA Pads 1-3.5 inch

1"-3.5" DA backing pads



Item No.	Size	Thread	Velcro	PSA	Max.RPM	Density	Hole	Weight	Foam Thickness
14410-11	1" (25mm)	1/4"-20 Int		✓	20000	Soft	no hole	n/a	10mm
14410-12	1" (25mm)	1/4"-20 Int	✓		20000	Soft	no hole	n/a	10mm
14412-11	1.2" (31mm)	1/4"-20 Int		✓	20000	Soft	no hole	n/a	10mm
14412-12	1.2" (31mm)	1/4"-20 Int	✓		20000	Soft	no hole	n/a	10mm



Item No.	Size	Thread	Velcro	PSA	Max.RPM	Density	Hole	Weight	Thickness
22120-11	2" (50mm)	5/16"-24		✓	20000	Medium	no hole	21g	9mm
22120-12	2" (50mm)	5/16"-24	✓		20000	Medium	no hole	21g	9mm
22120-21	2" (50mm)	M6		✓	20000	Medium	no hole	21g	9mm
22120-22	2" (50mm)	M6	✓		20000	Medium	no hole	21g	9mm
22130-11	3" (74mm)	5/16"-24		✓	20000	Medium	no hole	28g	10mm
22130-12	3" (74mm)	5/16"-24	✓		20000	Medium	no hole	28g	10mm
22130-21	3" (74mm)	M6		✓	20000	Medium	no hole	28g	10mm
22130-22	3" (74mm)	M6	✓		20000	Medium	no hole	28g	10mm



Item No.	Size	Thread	Velcro	PSA	Max.RPM	Density	Hole	Weight	Thickness
22330-021	3" (74mm)	M8 or 5/16"	✓		20000	Medium	no hole	30g	10mm
22330-121	3" (74mm)	5/16"-24	✓		20000	Medium	no hole	30g	10mm
22330-221	3" (74mm)	1/4"-20	✓		20000	Medium	no hole	30g	10mm
22336-121	3" (74mm)	5/16"-24	✓		20000	Medium	6	30g	10mm

* Optional through hole version for M8 or 5/16" bolt



Item No.	Size	Thread	Velcro	PSA	Max.RPM	Density	Hole	Weight	Thickness
26030-1	3" (74mm)	5/16"-24		✓	12000	Soft / Medium	no hole	80g	13mm
26030-2	3" (74mm)	5/16"-24	✓		12000	Soft / Medium	no hole	80g	13mm
26035-1	3.5" (89mm)	5/16"-24		✓	12000	Medium	no hole	85g	13mm
26035-2	3.5" (89mm)	5/16"-24	✓		12000	Medium	no hole	85g	13mm



Item No.	Size	Thread	Velcro	PSA	Max.RPM	Density	Hole	Weight	Thickness
23232-1	3" (70mm)	5/16"-24		✓	12000	Soft	no hole	35g	20mm
23232-2	3" (70mm)	5/16"-24	✓		12000	Soft	no hole	35g	20mm

3.6 Dust Free DA Pads



8+6/8+1
(Universal Pattern)

Dual Action Sander Backing Pads with Side Hole

- PUR molded, Medium density, good durability.
- Pad with optional bolt for 5/16"-24 and M8
- Better cooling and less dust while sanding

Mounting Accessories:



Item No.	Size	Thread	Velcro	PSA	Max.RPM	Density	Hole	Weight	Thickness
21780-02	6" (148mm)	M8 & 5/16"	✓		12000	Medium	8+6/8+1	125+/-3g	11.5mm



3+3+1

Soft Density Dual Action Sander Backing Pads

- Side and center holes to benefit dust suction performance
- Soft density, ideal for fine sanding or primer sanding



Item No.	Size	Thread	Velcro	PSA	Max.RPM	Density	Hole	Weight	Thickness
25150-11	5" (123mm)	5/16"-24		✓	12000	Soft	3+3+1	100+/-3g	11.5mm
25150-12	5" (123mm)	5/16"-24	✓		12000	Soft	3+3+1	100+/-3g	11.5mm

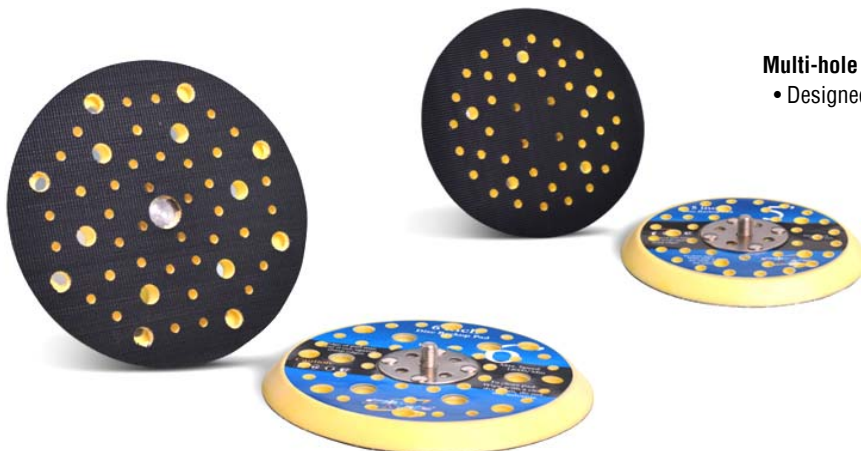

Multi-hole DA pads

- Designed to work with net abrasive for dust-free sanding

Item No.	Size	Thread	Velcro	PSA	Max.RPM	Density	Hole	Weight	Thickness
21650-2	5" (123mm)	5/16"-24	✓		12000	Medium	44	100g	9.5mm
21660-2	6" (148mm)	5/16"-24	✓		12000	Medium	53	125g	8.5mm

Dust Devil™ V3 New Concept Dust-Free Sanding Pad

- Creative dust cover design.
- Universal hole pattern.
- Available with medium and soft density.
- Pad is well balanced for smooth sanding.
- Fixed-bolt or changeable-bolt version.
- Changeable-bolt version fits Festool/Rupes/Makita Sanders.



Item No.	Size	Thread	Velcro	PSA	Max.RPM	Density	Hole	Weight	Thickness
23860-021	6" (148mm)	M8 and 5/16"	✓		12000	Medium	8+6+1	145g	12mm
23862-021	6" (148mm)	M8 and 5/16"	✓		12000	Medium	8+1	145g	12mm
23866-021	6" (148mm)	M8 and 5/16"	✓		12000	Medium	8+6-8+1	145g	12mm
23868-021	6" (148mm)	M8 and 5/16"	✓		12000	Medium	8+8+1	145g	12mm
23860-121	6" (148mm)	Fixed 5/16"	✓		12000	Medium	8+6+1	130g	12mm
23862-121	6" (148mm)	Fixed 5/16"	✓		12000	Medium	8+1	130g	12mm
23866-121	6" (148mm)	Fixed 5/16"	✓		12000	Medium	8+6-8+1	130g	12mm
23868-121	6" (148mm)	Fixed 5/16"	✓		12000	Medium	8+8+1	130g	12mm

Mounting Accessories:



Fits Disc Hole Pattern:

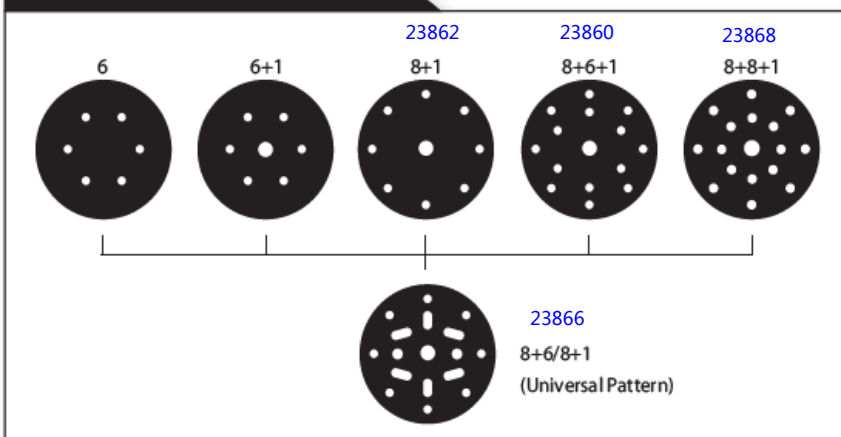

Pads are available for soft density in white color, e.g. 23860S-021 for soft version.

3.8 Dust Devil™ V2 DA Pads

Dust Devil™ V2 DA Backing Pads for FESTOOL Sanders

- Patented 2-layer structure and unique interior air flow channel, with side dust absorption feature, improve the cleaning and keep the regional temperature well-distributed in each area of the sanding disc.

- Upper black layer in medium density which is tough, lower white layer in soft density, this structure makes the pad tough enough to withstand aggressive operation, and keep soft interface between sander and workpiece for fine sanding finish.

- With variety of hole configurations, match the vast majority of sanding disc in the market.

- The smart mounting system offers 5/16"-24 bolt to match conventional air sander, M8 with adaptor to match Festool Sander.



Item No.	Size	Thread	Velcro	PSA	Max.RPM	Density	Hole	Weight	Thickness
21960-022	6" (148mm)	M8 and 5/16"	✓		12000	Medium	8+6+1	130g	14mm
21961-022	6" (148mm)	M8 and 5/16"	✓		12000	Medium	6+1	130g	14mm
21962-022	6" (148mm)	M8 and 5/16"	✓		12000	Medium	8+1 (Festo)	130g	14mm
21963-022	6" (148mm)	M8 and 5/16"	✓		12000	Medium	8+6+6+1	130g	14mm
21964-022	6" (148mm)	M8 and 5/16"	✓		12000	Medium	8+1(C=65)	130g	14mm
21965-022	6" (148mm)	M8 and 5/16"	✓		12000	Medium	53	130g	14mm
21966-022	6" (148mm)	M8 and 5/16"	✓		12000	Medium	8+6-8+1	130g	14mm
21967-022	6" (148mm)	M8 and 5/16"	✓		12000	Medium	Multi-air	130g	14mm

Remark:

- Fixed 5/16"-24 bolt is also available, e.g. 21960-122 for fixed bolt.

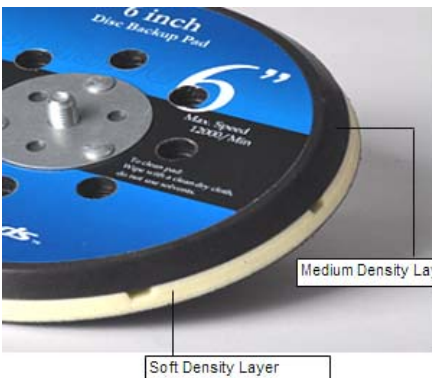

The content of mounting accessories for Dust Devil™ Pads

Changeable 5/16"-24 thread to match the conventional pneumatic sander,
M8 thread to match Festool Sander.



Best Selling Items:



3.9 Interface Pads

Interface Cushion pads with extra-soft foam layer



Item No.	Size	Foam Thickness	Hole	Density	Remark
72200	6" (148mm)	10mm	no hole	Extra Soft	
72201	6" (148mm)	10mm	8+6+1	Extra Soft	
72202	6" (148mm)	10mm	53	Extra Soft	
72204	6" (148mm)	10mm	6+1	Extra Soft	
72205	6" (148mm)	10mm	6	Extra Soft	
72207	6" (148mm)	10mm	8+1	Extra Soft	
72208	6" (148mm)	10mm	8+6-8+1	Extra Soft	
72209	6" (148mm)	10mm	8+8+1	Extra Soft	
72220	5" (123mm)	10mm	no hole	Extra Soft	
72221	5" (123mm)	10mm	5+1	Extra Soft	
72222	5" (123mm)	10mm	44	Extra Soft	
72223	5" (123mm)	10mm	3+3	Extra Soft	
72224	5" (123mm)	10mm	8+1	Extra Soft	
72226	5" (123mm)	10mm	5	Extra Soft	
72227	5" (123mm)	10mm	3+3+1	Extra Soft	
72240	3" (74mm)	10mm	n/a	Extra Soft	
72245	3" (74mm)	6mm	n/a	Extra Soft	
72246	3" (74mm)	6mm	3	Extra Soft	
72250	2" (50mm)	10mm	n/a	Extra Soft	
72255	2" (50mm)	6mm	n/a	Extra Soft	

Interface Cushion pads , higher density foam layer, super tough



Item No.	Size	Foam Thickness	Hole	Density	Remark
72229	6" (148mm)	10mm	6 Hole	Medium	White Foam
72225	5" (123mm)	12mm	n/a	Medium	White Foam
72241	3" (74mm)	12mm	n/a	Medium	White Foam
72301	75x100mm	20mm	n/a	Medium	White Foam, Rectangle
72302	75x100mm	15mm	n/a	Medium	White Foam, Rectangle

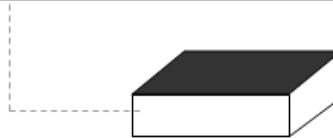

Pad velcro protector



Item No.	Size	Foam Thickness	Hole	Density	Remark
72281	5" (123mm)	n/a	no hole	n/a	
72285	5" (123mm)	n/a	44	n/a	
72288	5" (123mm)	n/a	3+3+1	n/a	
72286	6" (148mm)	n/a	53	n/a	
72282	6" (148mm)	n/a	15	n/a	
72283	6" (148mm)	n/a	6	n/a	
72284	6" (148mm)	n/a	8+1	n/a	
72287	6" (148mm)	n/a	8+6-8+1	n/a	
72290	6" (148mm)	n/a	8+8+1	n/a	

Multi-Hole Adaptor



Item No.	Size	Foam Thickness	Hole	Density	Remark
72289	5" (123mm)	6mm	multi-hole	Medium	

PSA-Velcro Converter



Item No.	Size	Cushion Thickness	Hole	Density	Remark
72291	2" (50mm)	n/a	no hole	n/a	PSA - Loop
72292	3" (75mm)	n/a	no hole	n/a	PSA - Loop
72291C	2" (50mm)	3	no hole	Medium	PSA - Loop
72292C	3" (75mm)	3	no hole	Medium	PSA - Loop

